

DOUBLE 3 GON SERIES

SKM
TRADE

Frézovacia hlava **-75%**
pri odbere 30ks došt. WNEX

ISO



Frézovací systém pre 90 ° frézovanie
na základe obojstrannej trigonálnej doštičky

- Čelné frézovanie
- Kontúrovanie
- Drážkovanie ponorným frézovaním
- Ponorné frézovanie
- Drážkovanie
- Frézovanie do rohu

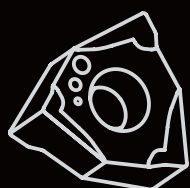

6 rezných hrán

Uhol nastavenia 90° zabezpečuje skutočný 90° rez v jednej frézovacej operácii a šetrí tak výrobný čas...

nixkoTOOLS

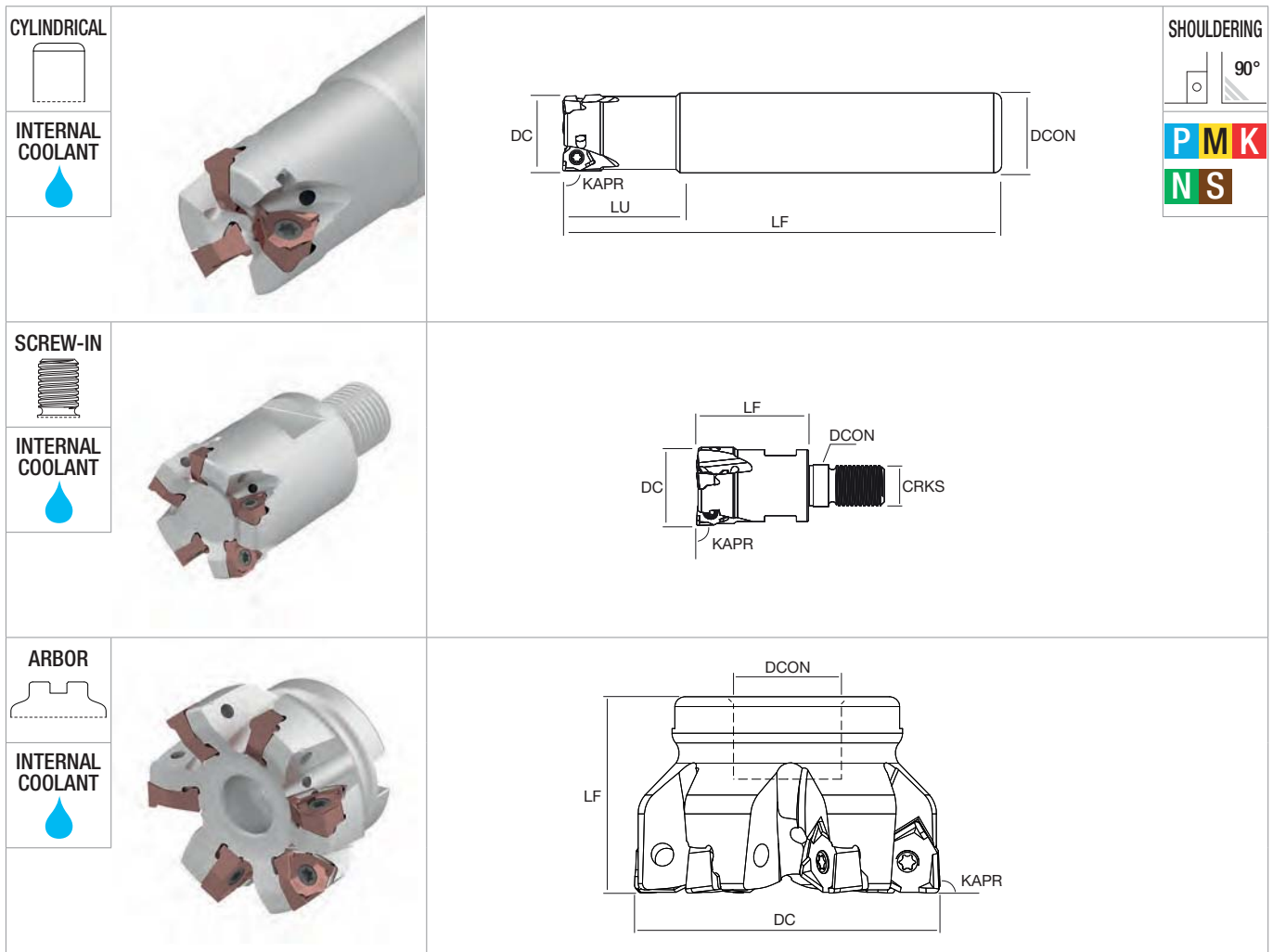

DOUBLE3GON Shouldering (KAPR 90°)		DC		DCON	LF	LU	CRKS		MIID
---------------------------------------------	--	----	--	------	----	----	------	--	------

	NT-WX04H	D020-S16-Z3	●	20	3	16	110	20	-	0.30	WNEX04
	D025-S20-Z4	●	25	4	20	120	22	-	0.50		
	D025-S25-Z4	●		4	25	120	30	-	0.50		
	D032-S25-Z5	●	32	5	25	130	25	-	0.80		
	D032-S32-Z5	●		5	32	130	40	-	0.80		
SCREW-IN		D020-M10-Z3	●	20	3	10.5	28	-	M10	0.10	
		D025-M12-Z4	●	25	4	12.5	30	-	M12	0.15	
		D032-M16-Z5	●	32	5	17	40	-	M16	0.25	
ARBOR	NT-WX04H	D040-F16-Z7	●	40	7	16	40	-	-	0.25	
		D050-F22-Z9	●								50
	NT-WX08H	D050-F22-Z4	●	50	4	22	40	-	-	0.45	
			●								5
		D063-F22-Z6	●	63	6	22	40	-	-	0.70	
			●								6
		D063-F22-Z7	●	63	7	22	40	-	-	0.80	
			●								7
		D080-F27-Z7	●	80	7	27	50	-	-	1.00	
			●								9
		D100-F32-Z8	●	100	8	32	50	-	-	1.60	
			●								11
D100-F32-Z11	●	100	11	32	50	-	-	1.60			
	●								11	40	63
D125-F40-Z11	●	125	11	40	63	-	-	2.40			
	●								11	40	63
D160-F40-Z12	●	160	12	40	63	-	-	4.00			
	●								12	40	63

WNEX		DOUBLE3GON				ISO513	HC-PVD				HC-CVD		HW							
							JP5530	JP5540	JP7525	JP8725	JP9540	JC7515	JC7530	JC8520	JU6520					
	Size	IC	S	D1	P	60 230	60 220		80 280			100 320								
	04	6.70	3.30	3.10	M	60 150	60 200			70 220										
	08	12.70	6.45	4.60	K			100 240			120 350	100 300								
					N								200 1000							
					S		40 100													
					H															
GRADE APPLICATION AREA		Light cut, stable machining			+ Hardness - Toughness +															
main application		Variable condition, general machining																		
applicable		Heavy cut, unstable machining																		
SHARP		SC P M S	WNEX 080604R-SC	RE 0.4 BS 1.8	$a_p \triangleright$ 0.50 $f_z \triangleright$ 0.08	4.00 0.14	7.00 0.20													
			WNEX 080608R-SC	RE 0.8 BS 1.5	$a_p \triangleright$ 1.00 $f_z \triangleright$ 0.10	4.00 0.16	7.00 0.22													
GENERAL		GP P M K	WNEX 040304R-GP	RE 0.4 BS 0.9	$a_p \triangleright$ 0.50 $f_z \triangleright$ 0.06	1.80 0.12	3.00 0.18													
			WNEX 080608R-GP	RE 0.8 BS 1.5	$a_p \triangleright$ 1.00 $f_z \triangleright$ 0.14	4.00 0.20	7.00 0.26													
REINFORCED		TE P K	WNEX 080608R-TE	RE 0.8 BS 1.5	$a_p \triangleright$ 1.00 $f_z \triangleright$ 0.14	4.00 0.22	7.00 0.30													
			WNEX 080612R-TE	RE 1.2 BS 1.1	$a_p \triangleright$ 1.00 $f_z \triangleright$ 0.14	4.00 0.24	7.00 0.34													
ALUMINIUM		AL N	WNEX 080608R-AL	RE 0.8 BS 1.4	$a_p \triangleright$ 1.00 $f_z \triangleright$ 0.10	4.00 0.17	7.00 0.24													

DOŠTIČKY		JP8725	JP5540	JP9540	JC7525	JU6520
GP	WNEX040304R-GP		8,42		8,42	
	WNEX080608R-GP	11,30	11,30	11,30	11,30	
SC,TE,AL	WNEX080608R-SC,TE,AL	11,30	11,30	11,30	11,30	11,80